

## **Development, Verification, and Validation of a Parametric Cervical Spine Injury Prediction Model**

A.R. Bonivtch, W. L. Francis, D.E. Moravits, G.R. Paskoff, B.S. Shender,  
C.R. Bass, S.R. Lucas, F.A. Pintar, N. Yoganandan, M.H. Koebbe,  
B.H. Thacker, and D.P. Nicolella

*This paper has not been screened for accuracy nor refereed by any body of scientific peers and should not be referenced in the open literature.*

### **ABSTRACT**

*The objective of this investigation is to develop a high fidelity, parametric finite element model of the cervical spine motion segment using a hierarchical model verification and validation approach. A technique has been developed to accurately describe the geometry of the cervical spine using a set of unique geometry parameters that are easily measured from clinical imaging systems such as Computed Tomography (CT) scans and to efficiently convert this geometry into a well-defined finite element model. Cervical spine parameters were measured from CT scans collected from a total of 73 volunteers, 50 male and 23 female. The parametric finite element model development includes a hierarchical model verification and validation (V&V) procedure that consists of verifying the model performance at increasing levels of complexity. Currently there are four levels. The first level is the component level and includes the individual soft tissue material properties such as the cervical ligaments. The next level is a meso-component level consisting of the behavior of the intervertebral disc via an isolated vertebral body-disc-vertebral body structural construct. The third hierarchical level consists of a complete motion segment with all associated soft tissue components. The fourth level is the full cervical column. Each level in the hierarchy builds on the previous level ensuring a systematic model V&V process (i.e., providing evidence the right answer is obtained for the right reason). This investigation will result in four verified and validated computational models of the cervical spine: a small female (106 lb - 120 lb), a large female (136 lb - 150 lb), a small male (166 lb - 180 lb), and a large male (226 lb - 240 lb). These models will be able to predict injury under a variety of loading conditions and will have many applications in the fields of biomechanics and auto safety.*

## INTRODUCTION

Cervical spine numerical modeling has many uses in areas such as accident reconstruction, injury biomechanics, surgical analyses, and kinematic studies. Other applications of numerical modeling include the study of morphology and architecture of hard tissues, ligament and disc characteristics, spinal loading, and muscle morphometry and action (Harrison et al 2004). Given the numerous applications of cervical spine model, it is imperative to ensure that a numerical model has been verified and validated for its intended use; a model is only meant to represent the conditions that it is validated in (Ng et al 2001).

Measured geometries of the cervical spine have been used to create numerous finite element models. In the model created by Ng et al (2001), and also used by Teo et al (2001), the geometry was created by digitally scanning a dried cervical spine specimen from a 68-year old man. Yang et al (1998) created a model using cervical spine geometry obtained from magnetic resonance imaging (MRI) of a 50th percentile male. The widely used KTH model was constructed using vertebral geometries based on the CT images of a 27 year old male, that were then scaled to those of a 50th percentile male (Brolin et al 2004). Although scaling techniques have been used to develop injury criteria for dummies of various sizes (Hilker et al 2002), this may not be a viable approach. The cervical spine geometry of females is not simply a scaled down male geometry (Mordaka et al 2003). Therefore, a parametric cervical spine model is needed to better represent the entire population that the model is going to represent. By employing a parametric finite element model approach, finite element models can be generated by simply inputting the new geometry parameter values saving time when numerous models are going to be created, and also allowing for probabilistic analyses.

Verification and validation studies form the crucial link between the development of the finite-element model and its ultimate intended use. They are the primary processes used in quantifying and building confidence in finite element models. Verification is the process of determining that a model implementation accurately represents the developer's conceptual description of the model and the solution to the model. Validation is the process of determining the degree to which a model is an accurate representation of the real world from the perspective of the intended uses of the model (American Institute of Aeronautics and Astronautics, Thacker 2003). In short, verification and deals with the mathematics associated with the model, whereas validation deals with the physics associated with the model (Roache 1998). Hierarchical verification and validation starts from the smallest components of a finite element model increasing in complexity to the complete system model (Figure 1). The response of the model is validated at each level before continuing on to the next without modifying model parameters at the complete model level to fit the experimental data.

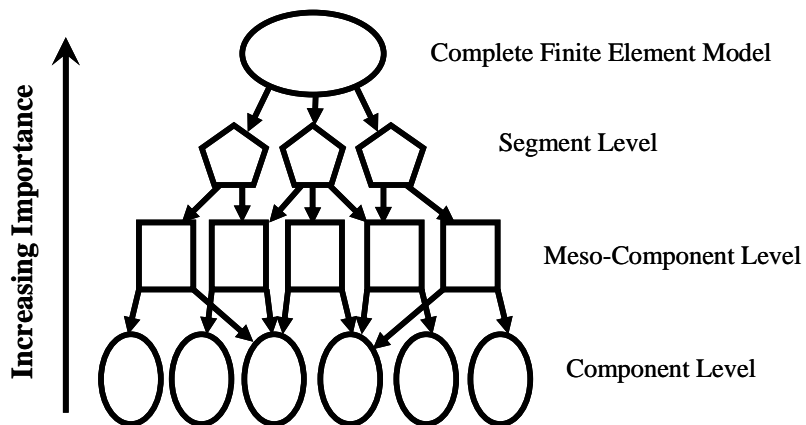

Figure 1: Verification and validation hierarchy.

The objective of this investigation is to develop a high fidelity, parametric finite element model of the cervical spine motion segment using a hierarchical model verification and validation approach. A technique will first be developed to accurately describe the geometry of the cervical spine using a set of unique geometry parameters that can be measured from Computed Tomography (CT) scans. The geometry

will then be used to create a well-defined finite element model. Finally, the model will be verified and validated using a hierarchical approach.

## METHODS

### Parametric Model Development

A parametrically defined cervical vertebra was defined using a parametric solid modeling software package (Pro/ENGINEER) (Figure 2a). The finite element mesh was then created using TrueGrid from a surface representation of the solid model exported from Pro/Engineer (Figure 2b). The mesh was constructed in several partitions to ensure uniform fidelity and to more easily accommodate, changes in the nominal motion segment geometry resulting from perturbations in geometry parameters. After the mesh was constructed, boundary conditions were assigned to the model, and a mesh refinement study was performed to determine the mesh that would be used for the probabilistic analysis.

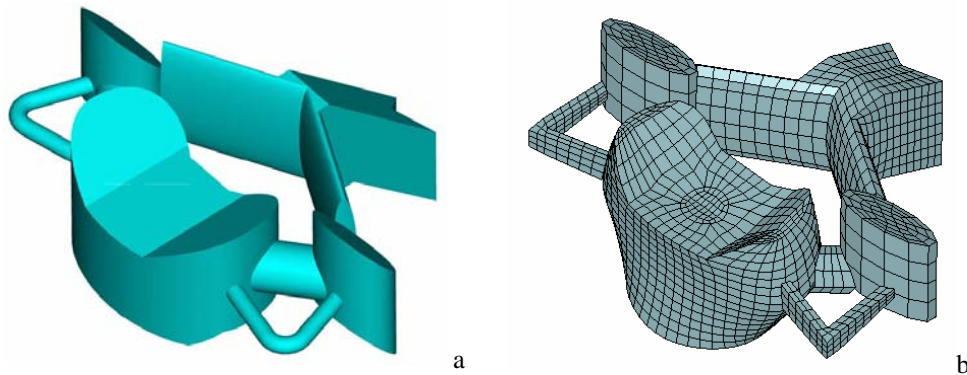

Figure 2: Parametrically defined (a) solid model of the cervical vertebra and (b) mesh.

### Geometry Parameter Measurement

CT scans of the cervical spine of 73 volunteers (23 female and 50 male) were obtained in digitized format. The CT image stacks were re-sliced to allow measurements on four different planes (Figure 3). A total of 35 parameters were measured for each vertebra, C3 through C7 (Figure 4). Four of the 35 parameters are angles, and were measured in degrees, whereas the remaining 31 parameters were measured in millimeters. A parameter index was included for each measurement: ap – articular process, pd – pedicle, sp – spinous process, tp – transverse process, and vb – vertebral body. All of the measurements were performed using a freely available image processing software package (ImageJ 1.34, National Institutes of Health, USA). A single researcher made all of the parameter measurements to maintain consistency and minimize error.

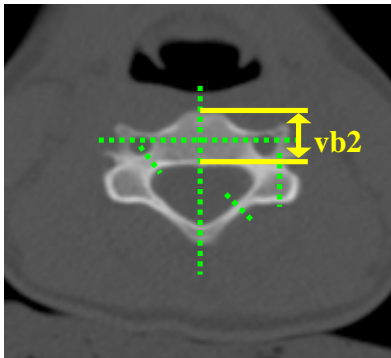

Figure 3: CT image slice of the cervical spine with dashed lines indicating the planes that re-slices were made on, and example of the vb2 measurement.

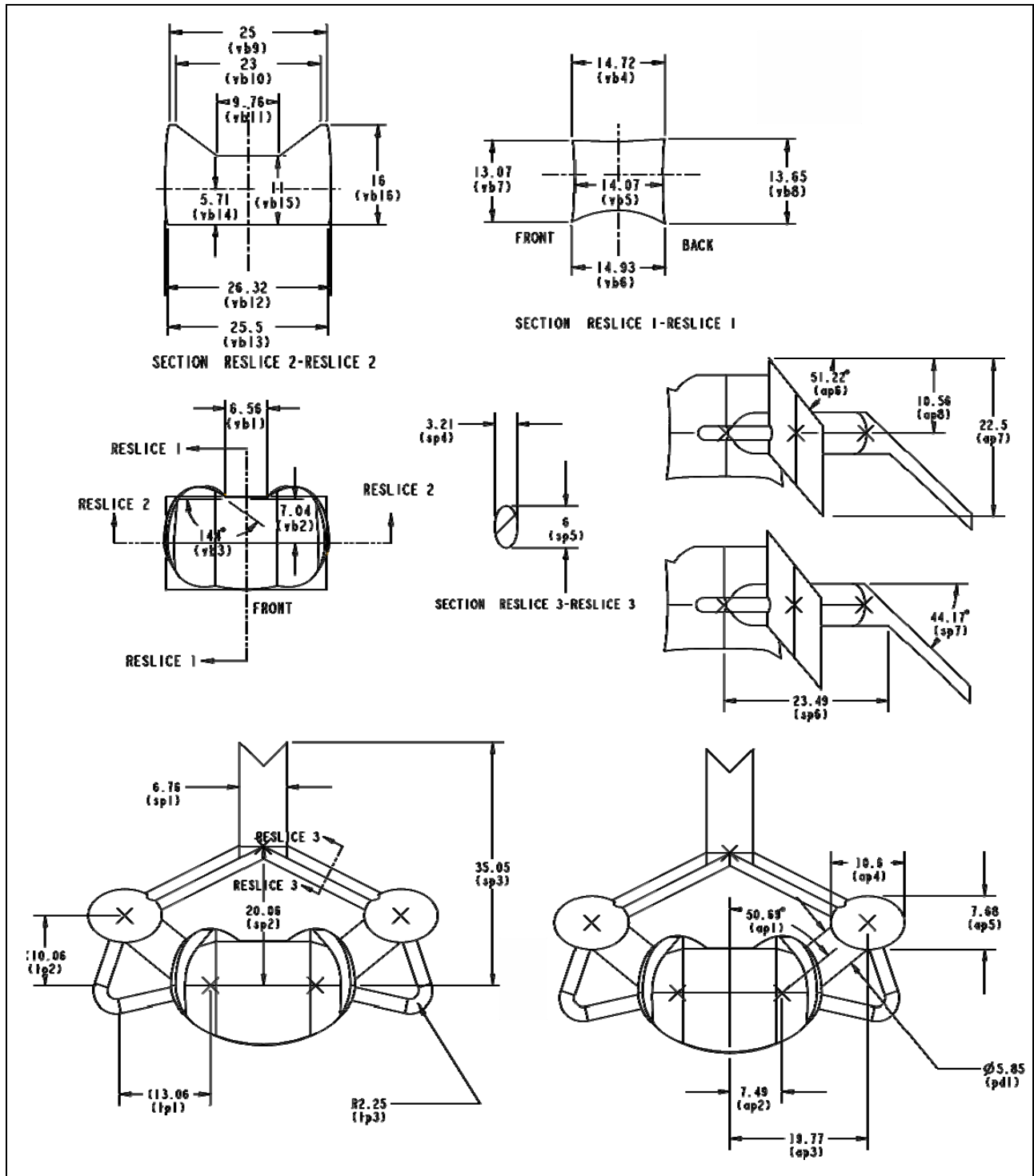

Figure 4: Diagram illustrating an example of the geometric parameters measured for each vertebra, C3 through C7 from the CT scans based upon the C5 vertebra solid model.

## Verification and Validation Level 1: Component

The model was verified and validated by using the hierarchical verification and validation approach as described by Thacker (2003). The first level investigated was the component level, which included the individual cervical ligaments soft tissue material properties. Quasi-static and dynamic *in situ* axial tensile tests were conducted on the anterior longitudinal ligament (ALL), the posterior longitudinal ligament (PLL), interspinous ligaments (ISL), joint capsule (JC) and ligamentum flavum (LF) (Yoganandan et al 2000). The results of these postmortem human subject (PMHS) specimen tests were used to define the geometry and material model parameters for each ligament. A transversely isotropic hyperelastic material model with viscoelasticity (LS-DYNA, LSTC, Livermore CA) was used in model the ligaments. Using an optimization routine, the ligament finite element material model parameters were fit to the test data. The finite element model of each of the ligaments (ALL, PLL, ISL, JC, LF) was then tested in the same conditions as the PMHS specimen tests were conducted and comparisons were made between their responses. Any changes that needed to be made to the finite element models of the ligaments were made at this level.

### **Verification and Validation Level 2: Meso-Component**

The next level was a meso-component level consisting of the behavior of the intervertebral disc, tested in tension and compression via an isolated vertebral body-disc-vertebral body structural construct. The finite element model of the disk consists of a viscoelastic annulus and a fluid nucleus. Again, laboratory tests were conducted and comparisons were made between the finite element model response and those of the PMHS specimens. Any changes that needed to be made to the intervertebral disc finite element model were made at this level.

### **Verification and Validation Level 3: Motion Segment**

The third hierarchical level consisted of a complete motion segment with all associated soft tissue components. At this level, each motion segment set (C3-C4, C4-C5, C5-C6, C6-C7) was tested in pure moment conditions using PMHS specimens (Wheeldon et al, 2006). The segments were loaded with a two Nm moment in flexion, extension, axial rotation, and lateral bending and the resulting rotations recorded. Comparisons were made to the finite models loaded under equivalent conditions. At this level no changes were made to the finite model to alter its response.

### **Verification and Validation Level 4: Full Cervical Spine**

The fourth and most complex level was the full cervical spine column tested in flexion, extension, axial rotation, and lateral bending. The C3 through T1 motion segment of PMHS specimens was constrained at T1 while it was loaded with a two Nm moment at C3 (Wheeldon et al, 2006). At this level, the finite element models of the vertebral bodies, intervertebral discs, and their corresponding soft tissues were assembled. No changes were made to the finite element model components when comparisons were made with the full cervical spine

## **RESULTS**

Once all of the parameters were measured from the volunteer CT scans, they were entered into a database. The values for the 35 parameters at each vertebral level were averaged into four different groups: small female (106 lb - 120 lb), large female (136 lb - 150 lb), small male (166 lb - 180 lb), and large male (226 lb - 240 lb). The resulting average parameters were input into the parametric finite element model resulting in the creation of four different finite element models (Figure 5).

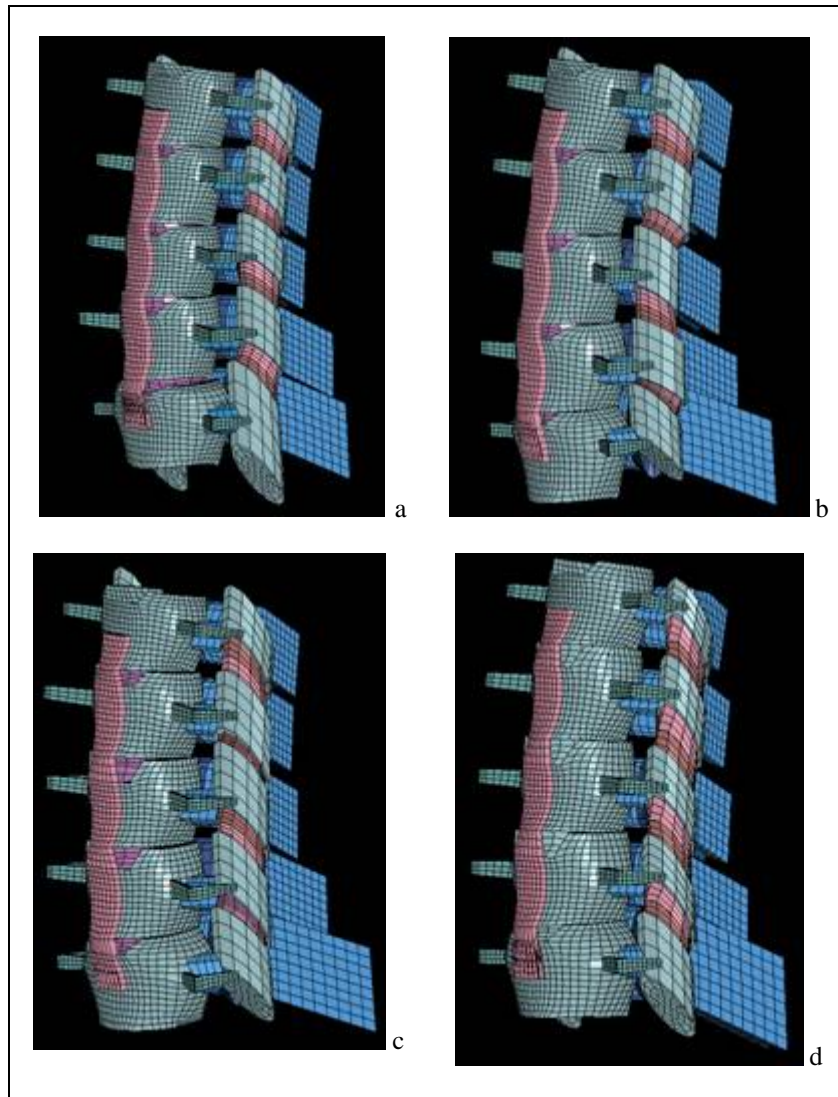

Figure 5: Finite element models created using the average geometry parameters for each weight group: (a) small female (106 - 120 lbs), (b) large female (136 - 150 lbs), (c) small male (166 - 180 lbs), and (d) large male (226 - 240 lbs).

### Verification and Validation Level 1: Component

The ligament finite element models compared well to both the quasi-static and dynamic experimental data (Figure 6 - 7). The ligaments presented in this report are not weight or gender specific, and so these material models were used in both weight groups of the male and female models. The static tests show that the ligaments have a non-linear component. Figure 6 shows that the soft tissue material model captures this behavior well. Dynamic relaxation tests were performed at 25% strain. The six term Prony series viscoelastic parameters were perturbed until the model's response fit the test data. Figure 7 shows that the model response fits the test results quite well.

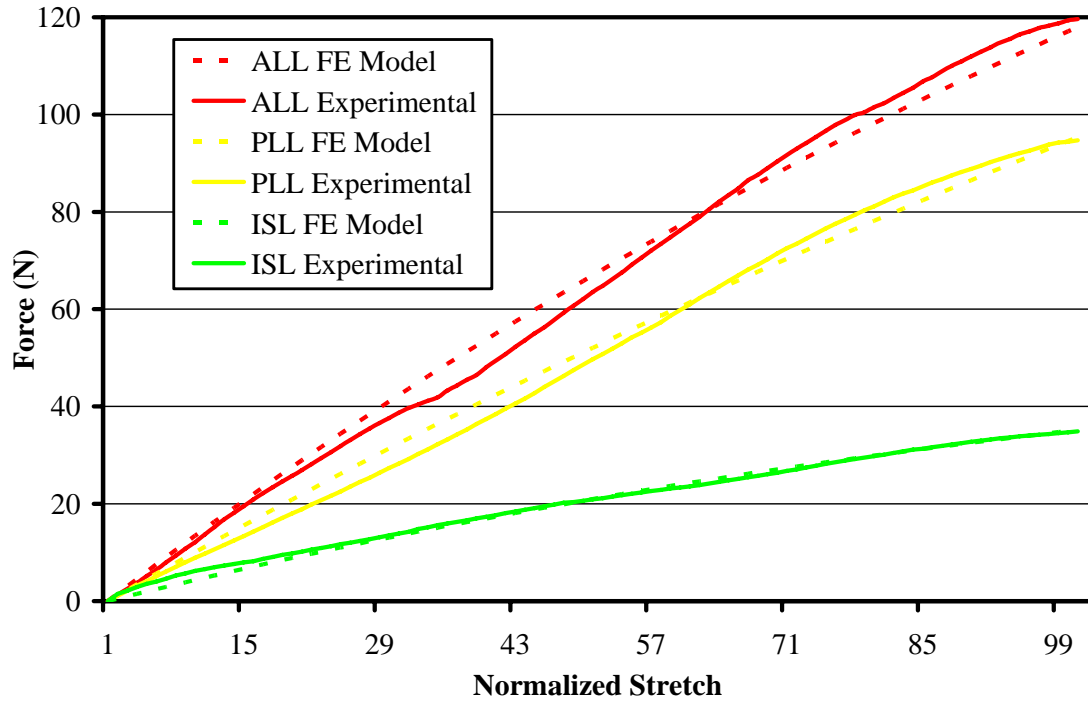

Figure 6: Ligament finite element (FE) models compared to the quasi-static experimental data for the ALL, PLL, and ISL.

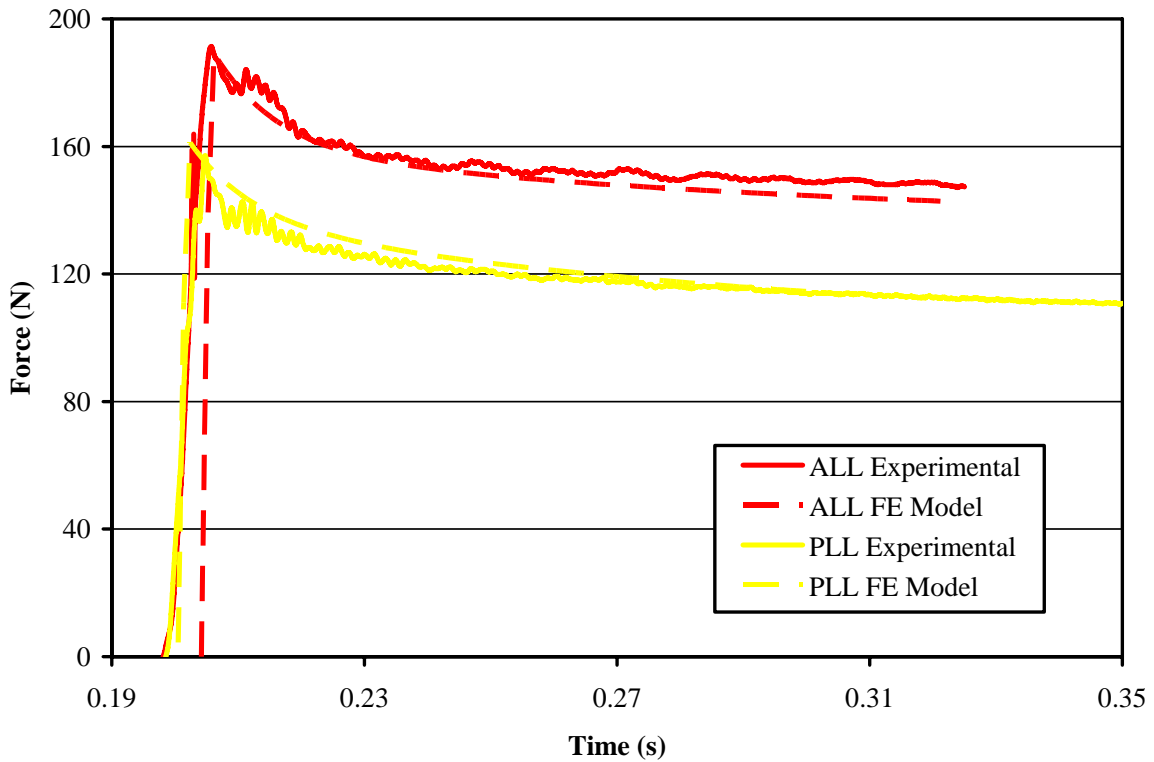

Figure 7: Ligament finite element (FE) models compared to the dynamic experimental data for the ALL and PLL.

## Verification and Validation Level 2: Meso-Component

The force versus displacement responses of the intervertebral discs varied between the male and female specimens tested in compression and tension. Due to the small number of specimens, only one intervertebral disc finite element model was created based upon the experimental results. The parameters of the material model were tuned to best fit both the compression and tension data of both the male and female specimens; this included the bulk modulus and viscoelastic parameters. The hysteresis response of the intervertebral disc PMHS specimens in tension and compression was well captured by the finite element model when it was tested in the same manner (Figure 8-9).

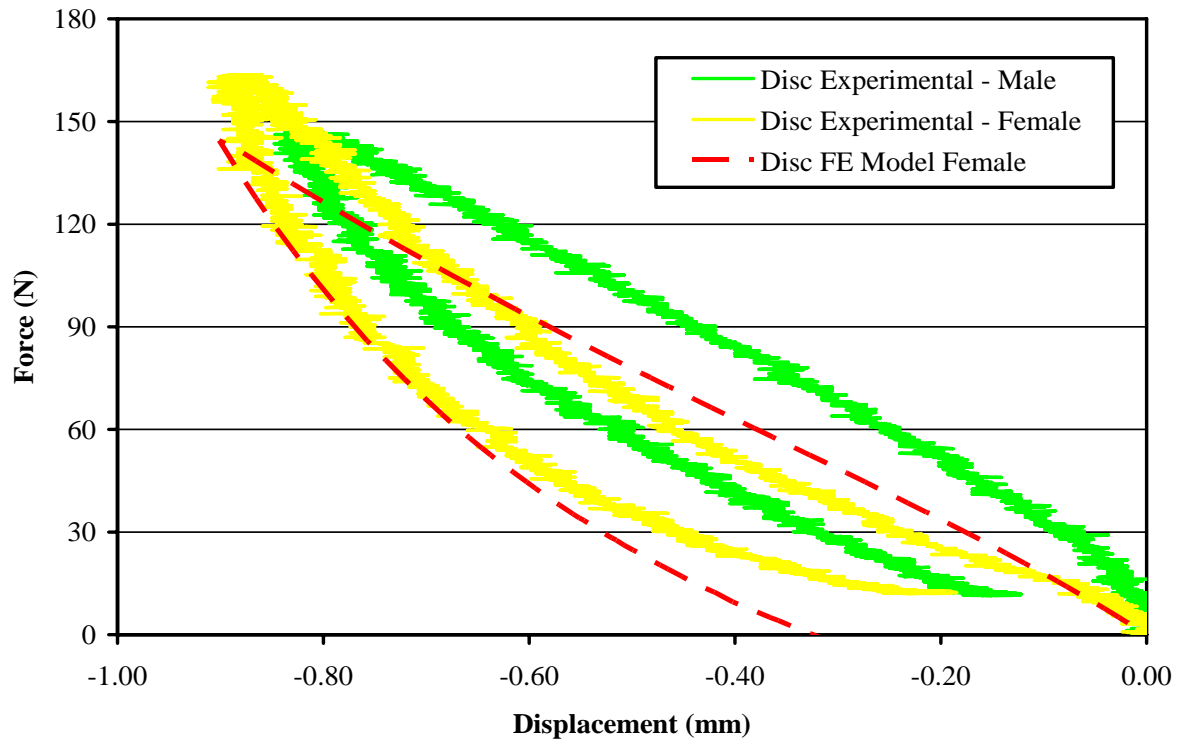

Figure 8: Disc finite element (FE) model compared to the experimental data for the disc in compression between two vertebral bodies.

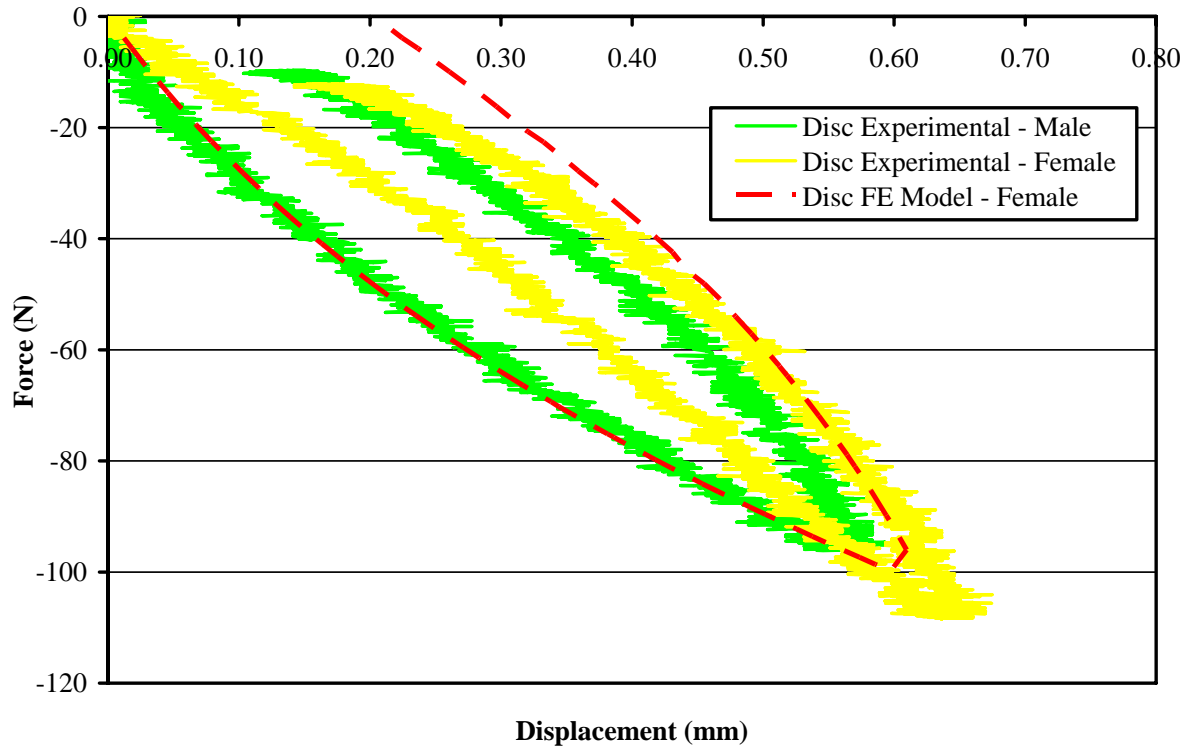

Figure 9: Disc finite element (FE) model compared to the experimental data for the disc in tension between two vertebral bodies.

### Verification and Validation Level 3: Motion Segment

Each of the finite element motion segments compared fairly well to the experimental data for all four of the weight groups in flexion, extension, axial rotation, and lateral bending. Several of these comparisons are described here (Figure 10-13). In the following figures, the solid green lines show the average response of the PMHS experiments bounded by plus and minus one standard deviation. The dashed red, yellow, light blue, and dark blue lines represent the small female, large female, small male, and large male finite element model responses respectively.

In the flexion and extension rotational responses of the motion segments, a “slack” effect can be seen (Figure 10-11). The initial portions of the responses have a large slope until to approximately 0.5 Newtons where the ligaments are not playing as large of a role. Once the ligaments have been stretched to a certain point, they influence the rotational response rather than the vertebral geometry or other factors.

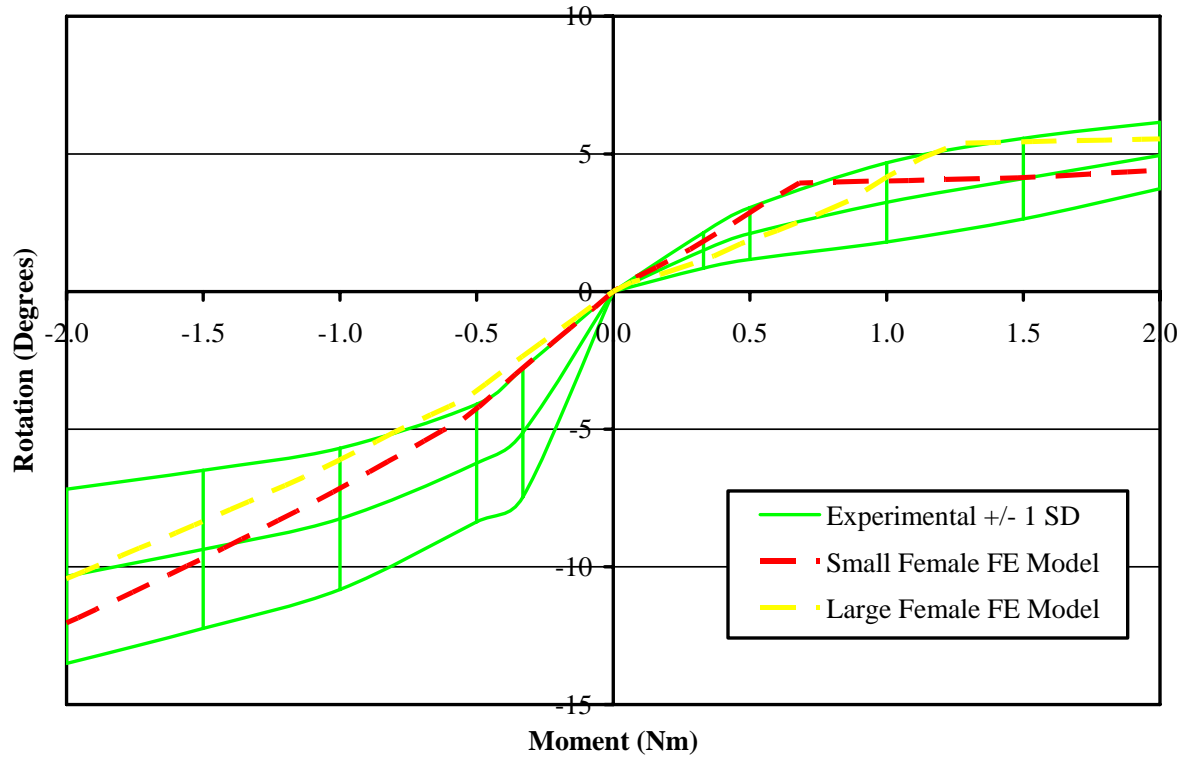

Figure 10: Finite element (FE) models compared to the experimental data for the C4-C5 motion segment rotational response in flexion and extension.

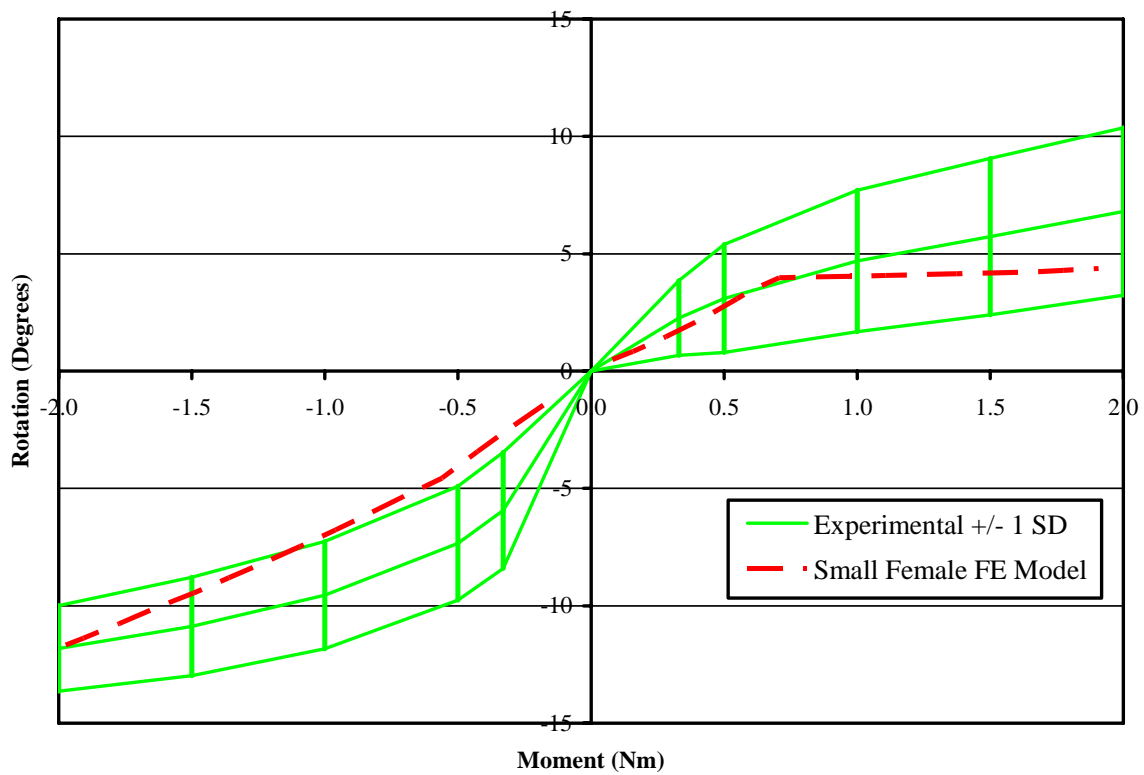

Figure 11: Finite element (FE) models compared to the experimental data for the C5-C6 motion segment rotational response in flexion and extension.

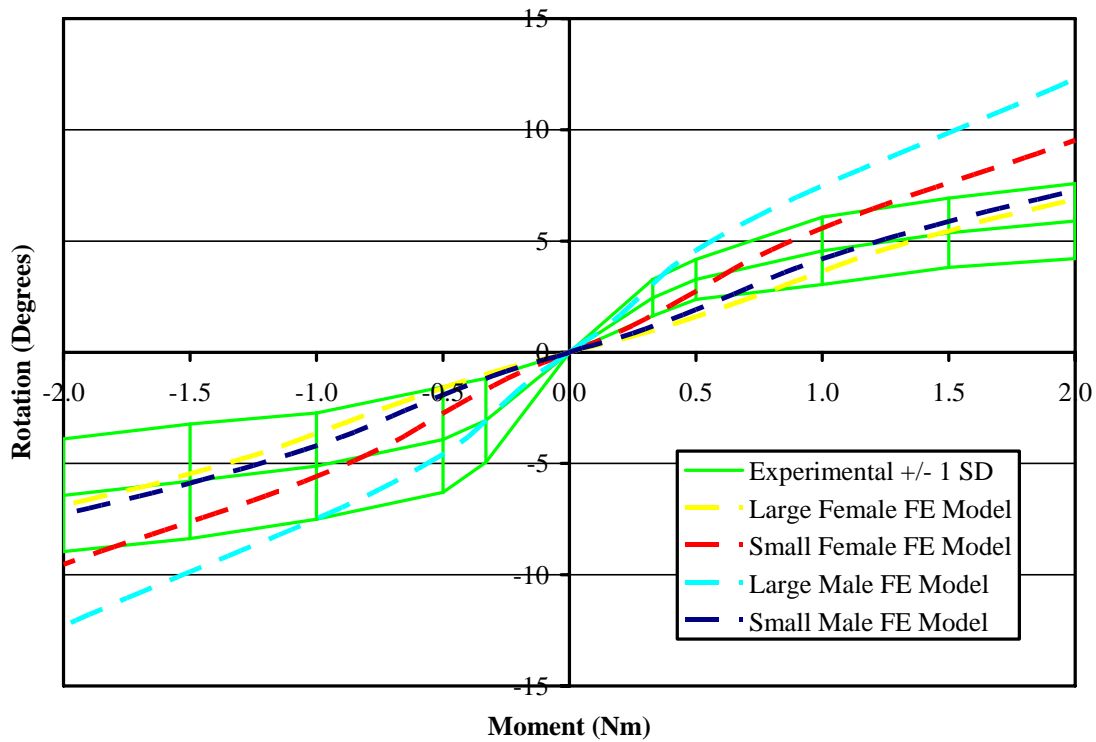

Figure 12: Finite element (FE) models compared to the experimental data for the C5-C6 motion segment rotational response in lateral bending.

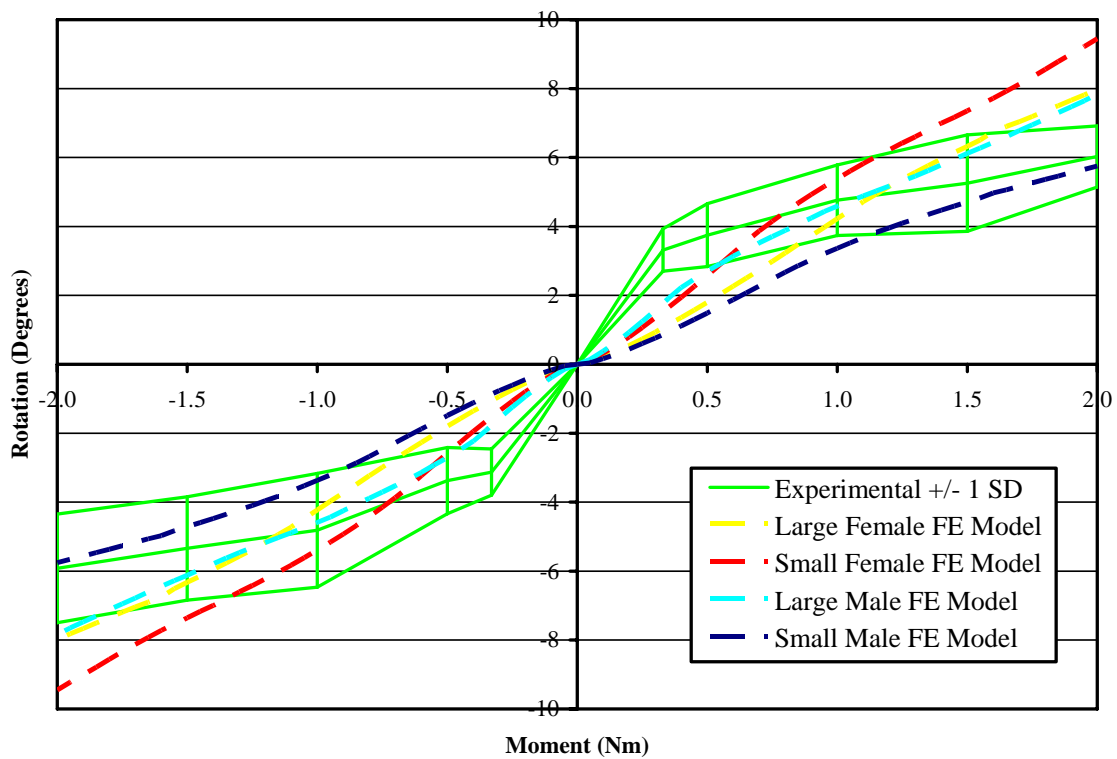

Figure 13: Finite element (FE) models compared to the experimental data for the C5-C6 motion segment rotational response in axial rotation.

## Verification and Validation Level 4: Full Cervical Spine

The full cervical spine column, from C3 to T1, will be tested in flexion, extension, axial rotation, and lateral bending. The initial results from this stage include the flexion and extension responses of the small female finite element model (Figure 14). The rotation-moment endpoints of both the flexion and extension responses of the small female finite element model fall on the average value of the PMHS responses. The entire response in extension in fact falls on the average if the PMHS responses. It is imperative to reiterate that the finite element model was built using the hierarchical verification and validation bottom up approach to achieve these results. The correct answers are being achieved for the right reasons.

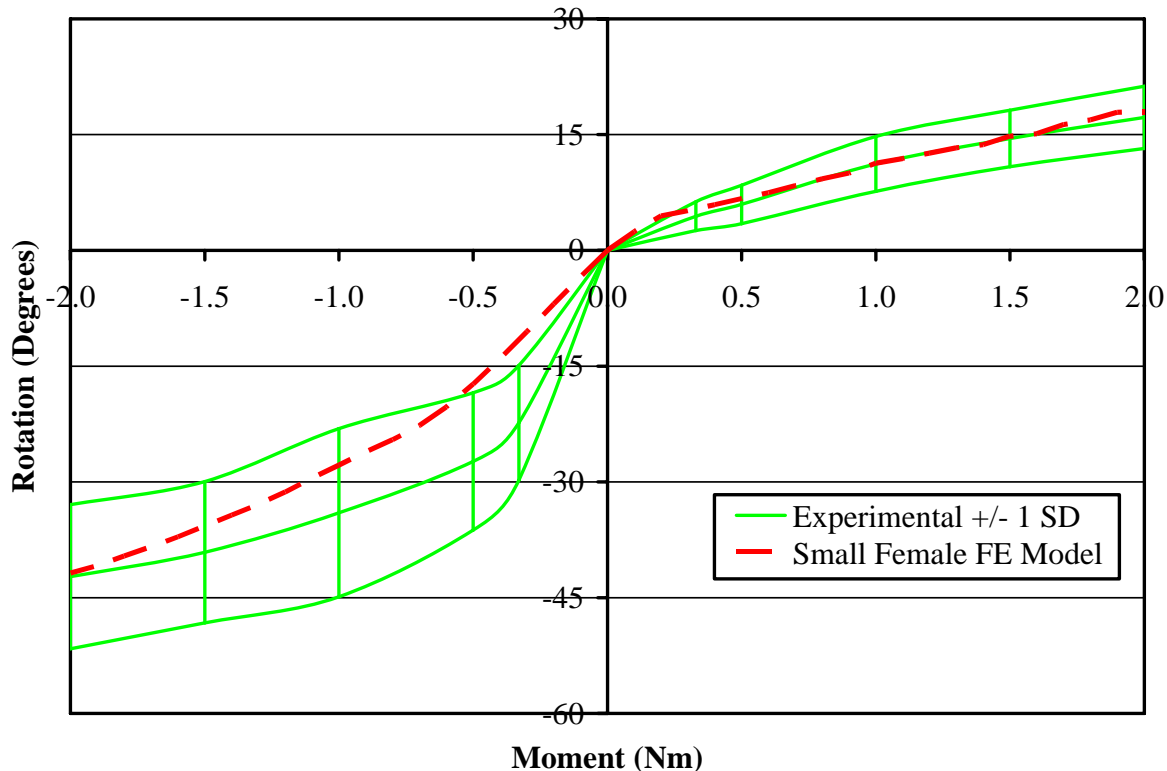

Figure 14: Small female finite element (FE) model compared to the experimental data for the full cervical spine (C3-T1) rotational response in flexion and extension.

## DISCUSSION

Because the cervical spine model presented here is parametric it offers distinct possibilities not offered by other cervical spine models. A personalized finite element model can be created for any individual who has a CT scanned performed. In a matter of hours, measurements can be taken from a patient's CT scan and input into the parametric finite element model. There are numerous applications for a model of this type. Additional weight groups can also be considered and the response of different spinal geometries can be investigated. This model is being used in probabilistic analyses, which will yield injury probability distributions and confidence levels. The model is currently used for military applications but can also be used in accident reconstruction and clinical applications.

The research and results presented here are a work in progress. Additional verification and validation will complete the four finite element cervical spine models. Injury thresholds and criteria will need to be incorporated into the model to make it a valuable injury prediction model. The near future plans for the model are to add the head through C2 vertebral geometries and their corresponding soft tissue and

musculature. The effects of active muscles will also be evaluated. Ultimately, the model will be extended to include the full spinal column.

## CONCLUSIONS

Four high fidelity parametric finite element models of the cervical spine have been created using a hierarchical model verification and validation approach: a small female (106 lb - 120 lb), a large female (136 lb - 150 lb), a small male (166 lb - 180 lb), and a large male (226 lb - 240 lb). A technique has also been developed to accurately describe the geometry of the cervical spine using a set of 175 unique geometry parameters that can easily be measured from CT images. These FE models will be able to predict injury under a variety of loading conditions and will have many applications in the fields of biomechanics and automotive safety.

## ACKNOWLEDGEMENTS

We would like to thank the Naval Air Warfare Center Aircraft Division (NAWCAD) for their continuing support of this project.

## REFERENCES

- AMERICAN INSTITUTE OF AERONAUTICS AND ASTRONAUTICS (1998). Guide for the verification and validation of computational fluid dynamics simulations. AIAA-G-077-1998: Reston, Virginia.
- BROLIN, K., and HALLDIN P. (2004). Development of a finite element model of the upper cervical spine and a parameter study of ligament characteristics. *Spine* 29(4), pp. 376-385.
- HARRISON, D. D., HARRISON, D. E., JANIK, T. J., CAILLIENT, R., FERRANTELLI, J. R., HAAS, J. W., and HOLLAND, B. (2004). Modeling of the sagittal cervical spine as a method to discriminate hypolordosis. *Spine* 29(22), pp. 2485-2492.
- HILKER, C. E., YOGANANDAN, N., and PINTAR, F. (2002). Experimental determination of adult and pediatric neck scale factors. Proc. 46th Stapp Conf, SAE Paper No. 2002-22-020.
- MORDAKA, J., and GENTLE, C. R (2003). Biomechanical analysis of whiplash injuries; women are not scaled down men. Proc. 4th European LS-DYNA Users Conference.
- NG, H. W., and TEO, E. C. (2001). Nonlinear finite-element analysis of the lower cervical spine (C4-C6) under axial loading. *J Spinal Disord Tech* 14(3), pp. 201-210.
- ROACHE, P. J. (1998). Verification and validation in computational science and engineering. Hermosa: Publishers: Albuquerque, NM.
- TEO, E. C., and NG, H. W. (2001). Evaluation of the role of ligament, facets and disc nucleus in lower cervical spine under compression and sagittal moments using finite element method. *Med Engr and Phys* 23, pp. 155-164.
- THACKER, B. H. (2003). The role of nondeterminism in verification and validation of computational solid mechanics models. Proc SAE 2003 World Congress and Exposition, SAE Paper No. 2003-01-1353.
- WHEELDON, J. A., PINTAR, F. A., KNOWLES, S., and YOGANANDAN, N. (2006). Experimental flexion/extension data corridors for validation of finite element models of the young, normal cervical spine. *J Biomechanics* (article in press).
- YANG, K. H., ZHU, F., LUAN, F., ZHAO, L, and BEGEMAN, P. C. (1998). Development of a finite element model of the human neck. Proc. 42nd Stapp Conf, SAE Paper No. 983157.
- YOGANANDAN, N., KUMARESAN, S., PINTAR, F. A. (2000). Geometric and mechanical properties of human cervical spine ligaments. *J Biomech Engr* 122, pp. 623-629.

Amber R. Bonivtch  
Reliability and Engineering Mechanics Section  
Mechanical and Materials Engineering Division  
6220 Culebra Rd, San Antonio, TX 78238-5166  
Phone: (210) 522-2129 Fax: (210) 522-6965  
Email: [amber.bonivtch@swri.org](mailto:amber.bonivtch@swri.org)

W. Loren Francis  
Reliability and Engineering Mechanics Section  
Mechanical and Materials Engineering Division  
6220 Culebra Rd, San Antonio, TX 78238-5166  
Phone: (210) 522-6647 Fax: (210) 522-6965  
Email: [loren.francis@swri.org](mailto:loren.francis@swri.org)

Donald E. Moravits  
Reliability and Engineering Mechanics Section  
Mechanical and Materials Engineering Division  
6220 Culebra Rd, San Antonio, TX 78238-5166  
Phone: (210) 522-2891 Fax: (210) 522-6965  
Email: [donald.moravits@swri.org](mailto:donald.moravits@swri.org)

Glenn R. Paskoff  
Code 4621  
MS 5, Bldg. 2187  
48110 Shaw Road  
Patuxent River, MD 20670-5304  
Phone: (301) 342-8469 Fax: (301) 342-8503  
Email: [PaskoffGR@navair.navy.mil](mailto:PaskoffGR@navair.navy.mil)

Barry S. Shender  
Bldg. 2187, Lab 1A92  
48110 Shaw Road, Unit 5  
Patuxent River, MD 20670-1906  
Phone: (301) 342-8881 Fax: (301) 342-8876  
Email: [barry.shender@navy.mil](mailto:barry.shender@navy.mil)

C.R. Dale Bass  
Center for Applied Biomechanics  
University of Virginia  
1011 Linden Ave  
Charlottesville, VA 22902  
Phone: (434)-296-7288 Fax:  
Email: [bass@virginia.edu](mailto:bass@virginia.edu)

Scott R. Lucas  
Center for Applied Biomechanics  
University of Virginia  
1011 Linden Ave  
Charlottesville, VA 22902  
Phone: (434)-296-7288 Fax:  
Email: [slucas@virginia.edu](mailto:slucas@virginia.edu)

Frank Pintar  
Department of Neurosurgery  
Neuroscience Research Labs 151  
VA Medical Center  
5000 W. National Ave  
Milwaukee, WI 53226  
Phone: (414) 384-2000 Fax: (414) 384-3493  
Email: [fpintar@mcw.edu](mailto:fpintar@mcw.edu)

Narayan Yoganandan  
Department of Neurosurgery  
Neuroscience Research Labs 151  
VA Medical Center  
5000 W. National Ave  
Milwaukee, WI 53226  
Phone: (414) 384-3453 Fax: (414) 384-3493  
Email: [yoga@mcw.edu](mailto:yoga@mcw.edu)

Matthew Koebbe  
GADAB Engineering  
#123  
1406 East Main Street, Suite 200  
Fredericksburg, TX 78624  
Phone: (830) 456-3879  
Email: [matthew@koebbe.net](mailto:matthew@koebbe.net)

Ben H. Thacker  
Reliability and Engineering Mechanics Section  
Mechanical and Materials Engineering Division  
6220 Culebra Rd, San Antonio, TX 78238-5166  
Phone: (210) 522-3896 Fax: (210) 522-6965  
Email: [ben.thacker@swri.org](mailto:ben.thacker@swri.org)

Daniel P. Nicolella  
Reliability and Engineering Mechanics Section  
Mechanical and Materials Engineering Division  
6220 Culebra Rd, San Antonio, TX 78238-5166  
Phone: (210) 522-3222 Fax: (210) 522-6220  
Email: [daniel.nicolella@swri.org](mailto:daniel.nicolella@swri.org)